



University of Regina
Faculty of Education

Educational Core Studies 100 (ECS) 100)
Knowledge, Schooling & Society

“A relational approach to decolonizing
education: working with the concepts of
invitation and hospitality”.

Fatima Pirbhai-Illich and Fran Martin

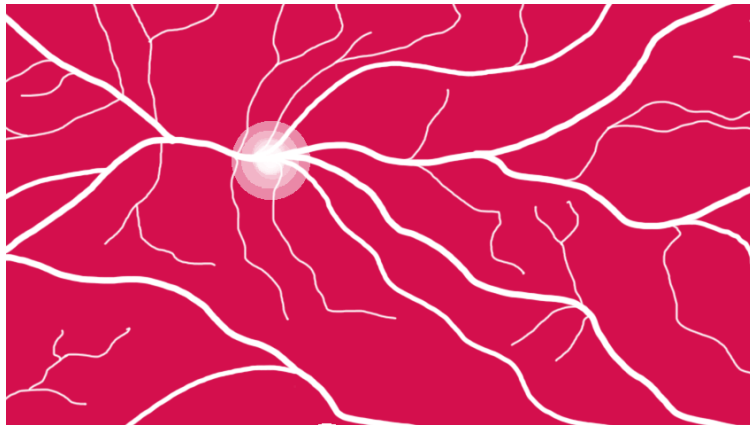

Source: <https://intercontinentalcry.org/resurgence-as-relationality/>

A relational approach to decolonizing education: working with the concepts of invitation and hospitality.

In this paper we identify some of the socio-cultural and historical influences on teacher identities. We then examine these and other influences on education from the perspectives of two contrasting ways of knowing. Our argument is that one way of knowing, object-based and colonial, has come to dominate all aspects of life on a global scale, including education. We go on to explore how the alternative way of knowing, relational and decolonial, might become part of teachers' practice by working with the concepts of invitation and hospitality.

Teacher worldviews

A worldview is a particular philosophy of life or conception of the world which may be expressed as an ideology or set of beliefs held about the world. Your worldviews shape your mindset – that is, your attitudes and opinions about something. Your worldview and the beliefs you hold are formed through the socialization processes of your upbringing – the socio-cultural groups you belong to, your family and community traditions and their historical and political contexts. These also affect your socio-cultural identities which in turn affect your *mindset*, how you act in the world and how you interpret your experiences in the world.

All of these influences affect you as a teacher, including your choice of teaching as a profession, your beliefs about the purposes of education, and your beliefs about what makes a good teacher. One of the key influences on your teacher identity will be the experiences you have had in the school system yourself, as a student. The types of schools you went to, the teachers you had, whether you felt you belonged in the school environment, the levels of success you experienced and the teaching & learning styles you encountered will all have influenced your beliefs about what makes a good teacher.

Your teacher identity is therefore developed over time through different socializing processes, including schooling. It is not something that is fixed or fully formed once you are qualified and start your career – it will continue to develop *but* it is likely to have a strong core (set of beliefs) that is relatively stable. Worldviews tend to be more stable than mindsets, but both will affect your teacher 'behaviours' – how you interact with students, your curriculum and pedagogical choices when planning, teaching and assessing and so on.

Different ways of knowing

While there are many ways of knowing, for the purposes of this paper we identify two fundamentally contrasting ways of knowing, **object-based** and **relational** (Martin & Pirbhai-Illich, 2016), that are connected to two worldviews and their ideologies, **colonial** and **decolonial**. Object-based thinking focuses on things in the world as objects that can be categorised and put into groups. For example, plants and animals are categorised in science according to their characteristics, creating a hierarchy of classifications in a tree-like structure (figure 1).

Figure 1: Scientific hierarchical classification structure

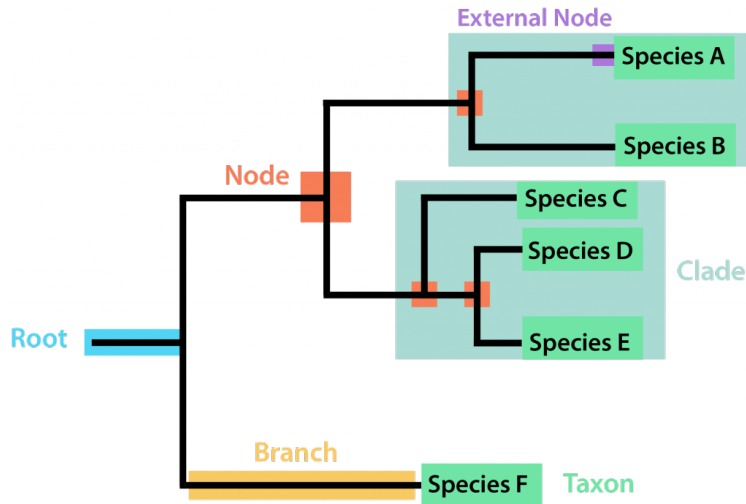

Source: <http://library.open.oregonstate.edu/microbiology/chapter/taxonomy-evolution/>

This tree-like structure is binary – that is, groups are created on the basis of whether certain features of an entity are like or not like the chosen characteristic. The root is the main category – for example animals. A node represents a point at which a characteristic divides the main category into two (a binary division) according to whether an animal has that characteristic or not – for example animals who are warm blooded and those who are not warm blooded. Further divisions might lead to ‘clades’ – for example, animals with the same characteristic (e.g. reptiles can all live in water and on land) but that are different in other respects (e.g. frogs, newts, crocodiles).

This way of thinking has its origins in Europe and has become the basis of Western ways of understanding the world. It is promoted as an objective, rational, and logical approach to making sense of phenomena and is often used to help people make decisions (figure 2) and as a means of developing critical thinking in educational contexts (figure 3). In figure 2, for example, decisions are supposedly made on a rational basis according to whether an individual answers ‘yes’ or ‘no’ to each question in turn. This requires the person making a decision to think in an either-or way. Nodes and branches are identified in the diagram are similar to the nodes and branches in figure 1, but the purpose of the categorisation is to make a decision rather than to classify animals.

Figure 2: A decision tree

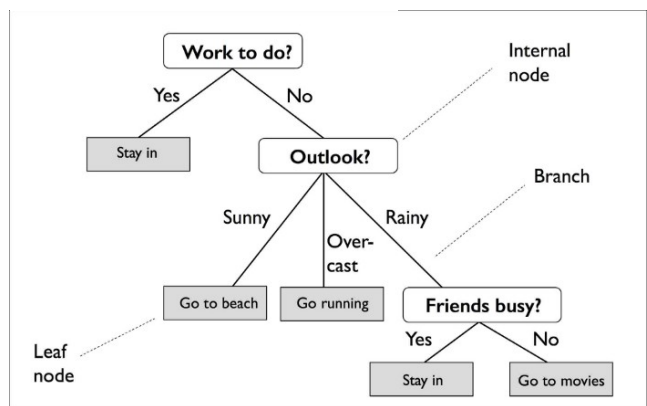

Source: <https://towardsdatascience.com/https-medium-com-lorri-classification-and-regression-analysis-with-decision-trees-c43cdb58054>

Figure 3: An example of a hierarchical classification structure for critical thinking

In this structure, because a distinction is made between lower order and higher order thinking, remembering and understanding are valued less than evaluating and creating

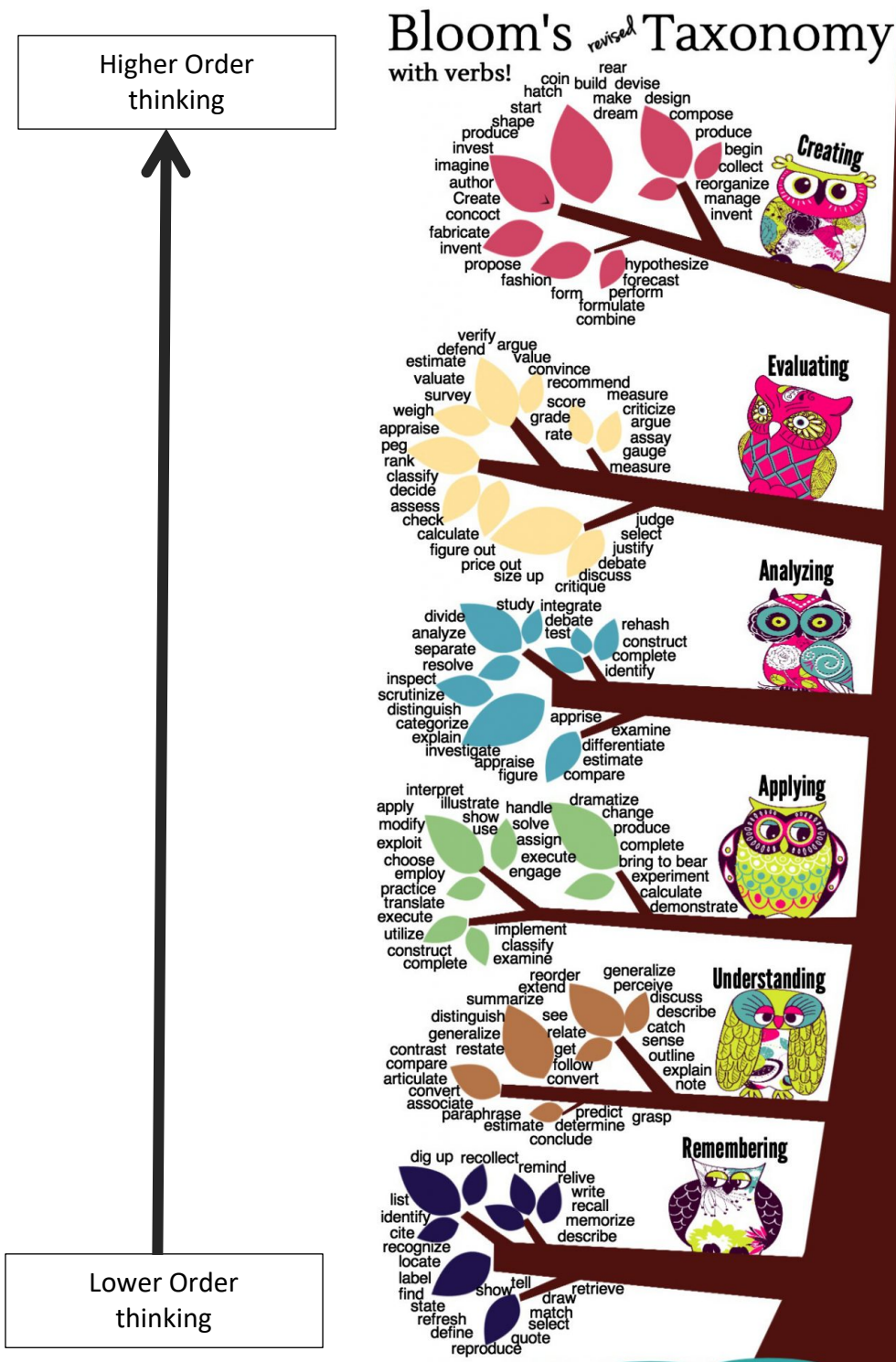

Source:
<https://www.teachthought.com/critical-thinking/taxonomy-tree-blooms-revised-taxonomy-graphic/>

Such hierarchical binaries can be seen in the distinctions of North-South, West and the Rest, wealthy – poor. A binary logic creates both a distance between ‘them’ and ‘us’ and reinforces ‘Othering’ (Said, 1979). Binaries are thus harmful to the ‘Other’: similarities are seen as ‘good’ / ‘normal’, while difference as ‘deviant’ / ‘problematic’. During the colonial spread from Europe across the world, object-based thinking became the means by which those in power (white Europeans) positioned themselves and their characteristics as the superior ‘norm’ against the people they encountered including Indigenous peoples, Africans and South East Asians. These people’s ways of being and knowing were judged as inferior. Educationally, this placed Western ways of thinking, acting and being firmly in the centre of the curriculum as of intrinsic value, while any alternatives were placed on the periphery and dismissed as either irrelevant or of little value.

Relational ways of knowing are based on the premise that everything and everyone is related and inter-connected in dynamic, inter-active, and mutually reciprocal relationships (Cajete,2000). Relational thinking is the basis of many Southern and Indigenous knowledges, including how knowledge is constructed, organised and disseminated. Within a relational tradition, knowledge of culture, identity and self only comes into being in each moment of relation with difference – through intercultural¹ relations. Cultural differences are revealed through relating to and with each other in a way that goes beyond visible differences to differences that are not so evident – such as family and community traditions and the cultural meanings that underpin them. If culture and identity are formed through relationships then they cannot be understood as fixed, bounded concepts; they are constantly made and remade through each moment of interaction. Likewise, heterogeneity is essential since it is only in relation to differences that one can understand one’s-self (or selves). Relational knowledges are therefore plural, situated, fluid and have porous boundaries; they are both a challenge to seeing knowledge as an object for consumption and to the dominance of any one knowledge structure since legitimacy and power are distributed, allowing for multiple voices and perspectives to be brought together in dialogue.

The problem with the object-based, colonial tradition is that it seeks to dominate and to use power to ensure that its way of thinking and being is the *only* way of thinking and being that is acceptable. The hegemony of coloniality has become global and affects every aspect of life including education. This is described by Grosfoguel (2011) as the Colonial World System. Colonial ways of thinking are therefore coercive, and we argue that teacher-student relations are also coercive in the ways in which students are told what to learn, how to behave, when it is time to learn a particular thing, and how to learn it. The challenge for teachers is how to develop relations with their students that are not coercive.

In the following section, we outline the work of Martin Buber (1958) whose ‘I-It’ and ‘I-Thou’ relations we equate with object-based and relational ways of being and knowing. We find Buber’s analysis of these two types of relation helpful in thinking about how each influences educational practices and therefore how teachers’ practices might become more decolonizing.

¹ Culture, in this context, is not equated with race or ethnicity. Neither is intercultural understood at the nation scale. We view culture in the broadest sense to include the everyday traditions and practices of families, communities and other groups that one might belong to. From this point of view all classroom relationships are intercultural.

Buber (1958) I-It and I-Thou relationships.

I-It is a relation of experience and sensation. 'I' stands in relation to 'it' as an object that is separate from the self, which we either use or experience. The object of experience (the It) is viewed as a thing to be utilized, a thing to be known or put to some purpose. In experience we see our object as a collection of qualities and quantities, as a particular point in space and time. There is a necessary distance between the experiencing of I and the experienced It: the one is subject, and the other object.

I-Thou is a spiritual relation. 'I' stands in relation to 'thou' not through seeking but through encounter. Encounter is *actual life*. It means suspending experiencing and just *being*. How can one stand in relation without experience? A Thou relation is life *with*, it is not experiencing something as an object or with objective; it is not internal making sense of an object experienced, it is a relation *between*, subject with subject, reciprocal and emergent (because it is without objective). These distinctions are summarised in the table below.

I-It orientation in teacher-student relations <i>"Doing to"</i>	I-Thou orientation in teacher-student relations <i>"Being with"</i>
<ul style="list-style-type: none"> • Object focused: subject-object relationship, indirect knowing & using the other • The world of the past and accumulated knowledge. • Objectives from past knowledge form the basis of learning – relations have an agenda • It / he / she is bound in context in space and time. • This requires only parts of oneself in the relationship – touch, cognition etc • It is therefore partial, fragmented 	<ul style="list-style-type: none"> • Relational: subject-subject reciprocal relationship, direct, present, mutual, open • The world met through encounter and in the present • Falls to you through will and grace, can't be sought – it is without agenda • It is not set in space and time. It's a living centre in the cosmos and involves the whole being, some call it love • It is a relation of togetherness, a 'with' that does not use, examine, understand or experience • It is a beingness, to be fully with another, a togetherness using the whole being • It is therefore authentic

Buber argues that 'Thou' is required for the me to become 'I'. **It is a necessary process of differentiation.** Once I become 'I' then I can say 'You/thou' (like a baby becoming aware of separation between self and parent/care-giver). This is similar to the pre-categorical understanding of difference. So difference is noted first before categories of I and You are created. From there the two I-It / I-Thou relationships develop.

However, Buber argues that life at a societal level, including education, overemphasises I-It relationships. For example, provincial curricula can be described as I-It because the objectives for learning are externally determined – e.g. the Saskatchewan Curriculum which provides objectives for

learning in specified curriculum areas (Arts, English Language Arts, Mathematics, Science, Social Studies and so on). While this might be necessary, an over-reliance on I-It is a curriculum of poverty in the sense that it lacks potential richness that can come through attention to I-Thou relationships. Buber (1958) says ‘without ‘It’ one cannot live, but he who lives with ‘It’ alone is not a man’ (p. 34) There is a need to move between the two – for example, taking knowledge in the classroom, the I assumes value in the curriculum, while the Thou assumes value in the cultural and home funds of knowledge of the learners. In the following section we outline how the concepts of invitation and hospitality can be helpful in developing I-Thou relations and bringing students’ funds of knowledge into the classroom.

Invitation and hospitality

There is nothing new in the idea that teachers have more success with their students when they create an inviting atmosphere in the classroom. Being inviting as a teacher focuses on how one relates to the students and how one creates a classroom space, both the social and physical environment, that motivates students to want to be there and to want to learn. In fact, there is a body of theory known as Invitational Theory that was developed in the 1970s by Purkey, Novak and Schmidt (Purkey & Novak, 1984; Purkey & Schmidt, 1987). However, although it focuses on developing (non-coercive) positive teacher-student relations, the theory was developed from the perspective of the western tradition and so the ways of being invitational, and the teacher qualities (caring, respectful) and behaviours (student-centred) that were valued, were western. The diagram below (figure 4) is taken from an online resource and represents how Indigenous ways of knowing and being see individuals in the context of all their relations. It is a holistic approach to understanding a person.

Figure 4: Indigenous ways of knowing and being²



² Source: <https://opentextbc.ca/indigenizationfrontlineworkers/chapter/indigenous-ways-of-knowing-and-being/>

When a student is understood holistically, a teacher does not only invite the student, but the student and *all* the student's relations, into the classroom space. This means inviting who the student is (rather than who the teacher would like the student to be) which in turn means getting to know who the student is in a holistic way (rather than making assumptions about who the student is based on dominant, racialized categorizations and stereotypes). We suggest an approach that involves accessing the student's Funds of Knowledge³ (Gonzalez, Moll & Amanti, 2005) which enable the teacher to access elements of the student's family, community and place-based knowledges – i.e. the knowledges that the student directly relates to. Once these funds of knowledge are available to the teacher, s/he has to find ways of incorporating them into learning activities, in other words to find ways of maintaining the I-It – I-Thou relation over time.

We therefore propose thinking of the teacher-learner relationship as intercultural, where the balance of power rests with the teacher but where that balance can be reduced by also thinking of the relation as similar to that of a host-guest. This requires the teacher to show a form of hospitality in which the teacher 'host identifies with the [student] guest and chooses not to live out of any privilege those resources offer, but rather to understand himself or herself as a recipient [or learner], too' (Oden, 2001:26). This is a challenging balance to achieve because, as Derrida (2000) points out, there is a paradox that is inherent to the host-guest relation. The host (teacher) has an orientation towards the guest (student) that is both open to the unexpected and to the differences that might be encountered; at the same time the host recognises that in order to be hospitable there is an assumption of ownership of the space into which the guest enters, over which the host has the power to extend or not extend hospitality. Equally, the student has the power to accept or reject the teacher's hospitality. For Derrida, hospitality is not therefore about hosting the other, but about an ethical response to the demand of heterogeneity/plurality - to ask how teachers might respond to student differences in ways that resist categorization, that blur the limits of the boundaries between school and home knowledges, and that challenge teachers to rethink mainstream ideas of what counts as the curriculum and education itself. Central to a decolonial approach to education is therefore an understanding of invitation and hospitality as elements of an ethical, reciprocal educational relationship in which teacher and student can be both host and guest, on a joint process of exploration, finding answers to shared questions that are authentic, the answers to which emerge from the relation and thus cannot be known in advance. A summary of the implications for teaching is shown in figure 5.

³ The authors define the key term "funds of knowledge" as the skills and knowledge that have been historically and culturally developed to enable an individual or household to function within a given culture, and argue that integrating funds of knowledge into classroom activities creates a richer and more-highly scaffolded learning experience for students.

Figure 5: Implications of alternative ways of knowing for teaching

Tradition	Ways of being	Ways of knowing	Perspective on culture	Ways of teaching
Object-based I-It	Self, other, environment and culture seen as separate entities	Knowledge exists separately from the knower and is thus objective; its structure is categorical, binary, hierarchical; it promotes either-or thinking; truths exist as certainties	Race and culture exist as things to be categorized and named; there is a unified understanding of categories as fixed and stable; Neutrality of self – the assumed normalcy and superiority of the dominant group’s norms	Teaching to, doing to, reliant on prescribed curriculum knowledge
Relational I-Thou	Self, other, environment and culture are inextricably bound together, interconnected	Knowledge is not separate from the knower; it is co-created through relation; it’s structure is pre-categorical and horizontal; it promotes both-and/also thinking; truths exist as provisionalities	Race and culture are socially constructed ‘realities’; categories exist but they are co-created, have porous boundaries, and are constantly being made and re-made. Subjectivity of self – locating identity in social, cultural and historical contexts	Teaching and learning with, being with, working with students’ home and cultural finds of knowledge Being inviting and hospitable

Final thoughts

The aim of this paper is to explore how it might be possible to expand teaching methods to include relational/decolonial ways of being and doing as teachers. This is *not* a replacement model that says everything about the object-based/colonial approach is incorrect and that we should only use relational/decolonial approaches. To argue for a replacement would be to set the two ontologies in opposition, requiring teachers to select either one or the other. Ours is an argument in support of expanding teacher ontologies and pedagogical repertoires, which asks teachers to use *both* object-based *and* relational approaches. In the same way, it is important to understand that colonial and decolonial are not at the opposite ends of the divide but that they hold a symbiotic relationship- we cannot have one without the other. There will always exist a tension between the two.

References.

Derrida, J. (2000). 'Hospitality' *Angelaki: Journal of the Theoretical Humanities*, 5 (3), 3–18.

Gonzalez, N., Moll, L. C., & Amanti, C. (2005). *Funds of knowledge: Theorizing Practice in Households, Communities, and Classrooms*. Mahwah, NJ: Lawrence Erlbaum

Grosfoguel, R. (2011). Decolonizing Post-colonial Studies and Paradigms of Political Economy: Transmodernity, Decolonial Thinking, and Global Coloniality. *TRANSMODERNITY: Journal of Peripheral Cultural Production of the Luso-Hispanic World*, 1(1), 1-37.

Martin, F. and Pirbhai-Illich, F. (2016). Towards Decolonising Teacher Education: Criticality, Relationality and Intercultural Understanding. *Journal of Intercultural Studies*, 37(4): 355-372.

Oden, A. (Ed.) (2001). *And you welcomed me: A sourcebook on hospitality in early Christianity*. Nashville: Abingdon.

Pirbhai-Illich, F., Pete, S. and Martin, F. (2017). *Culturally Responsive Education: Working Towards Decolonisation, Indigeneity and Interculturalism*. London: Palgrave Macmillan.

Purkey, W., & Novak, J. (1984). *Inviting school success: A self-concept approach to teaching, learning, and democratic practice*. Belmont, CA: Wadsworth.

Purkey, W. W. and Schmidt, J. J. (1987). *The Inviting relationship: An expanded perspective for professional counselling*. Prentice-Hall, Englewood Cliffs, New Jersey